

Technical
Drawing

Desenho
Técnico

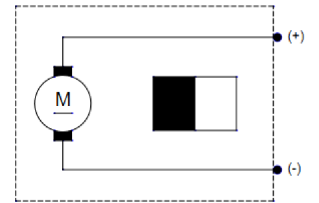
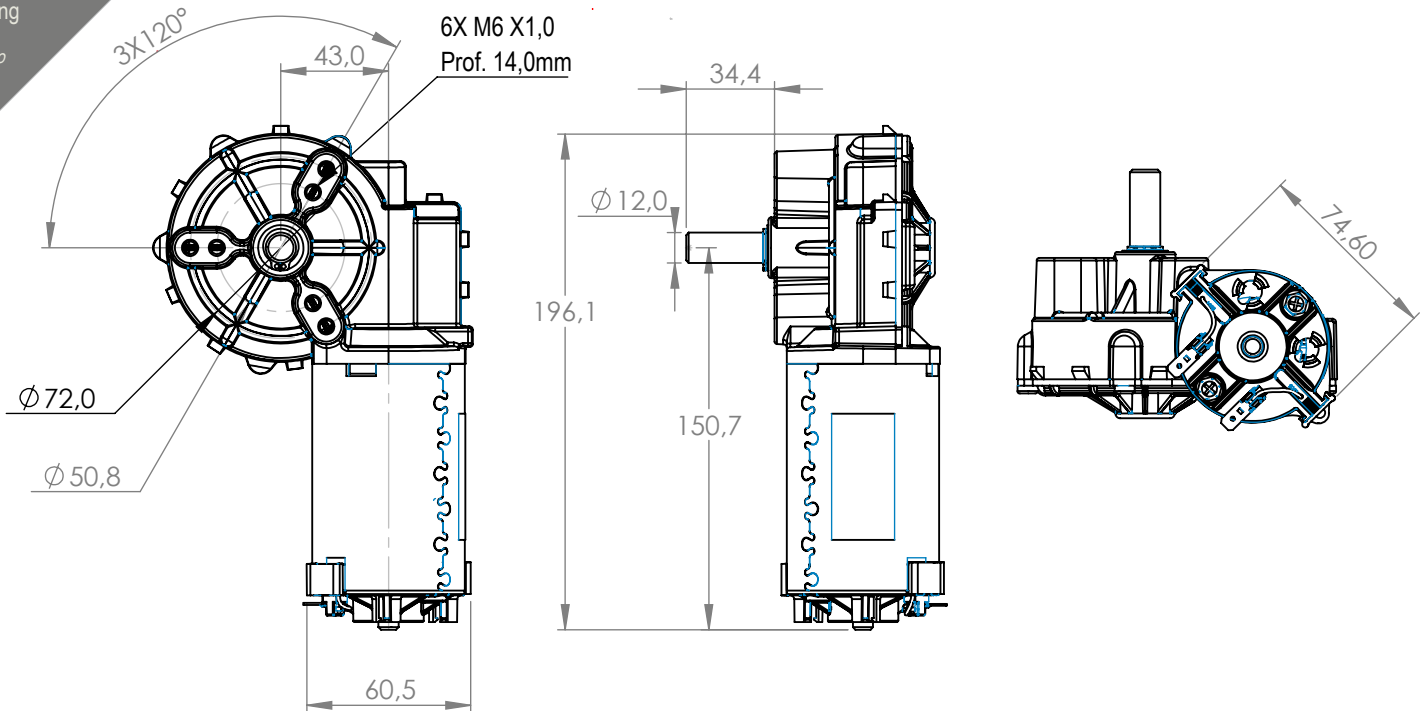

Technical
Specification

Especificação
Técnica

Imagem
Ilustrativa

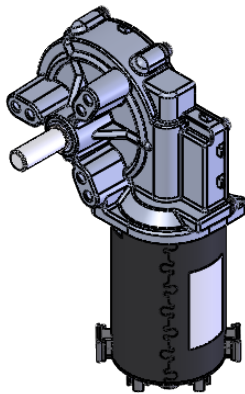

100503012

| CARACTERÍSTICAS ELÉTRICAS | |
|---------------------------|-------|
| U _N (V) | 13 |
| P _N (W) | 54 |
| n _N (rpm) | 89 |
| I _N (A) | 5 |
| I _{max} (A) | 58 |
| M _N (Nm) | 6 |
| M _{max} (Nm) | 35 |
| i | 55:1 |
| Rotação | L / R |
| Peso (Kg) | 1,300 |

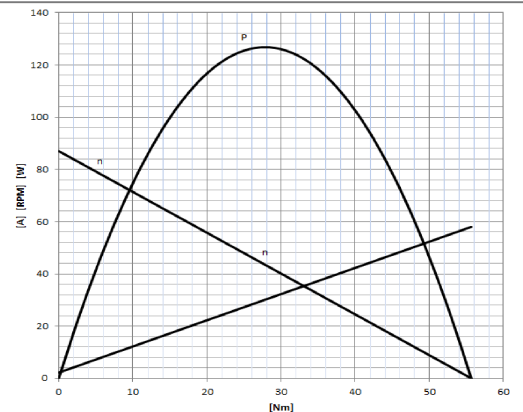

100503024

| CARACTERÍSTICAS ELÉTRICAS | |
|---------------------------|-------|
| U _N (V) | 27 |
| P _N (W) | 56 |
| n _N (rpm) | 82 |
| I _N (A) | 4 |
| I _{max} (A) | 30 |
| M _N (Nm) | 6 |
| M _{max} (Nm) | 35 |
| i | 55:1 |
| Rotação | L / R |
| Peso (Kg) | 1,300 |

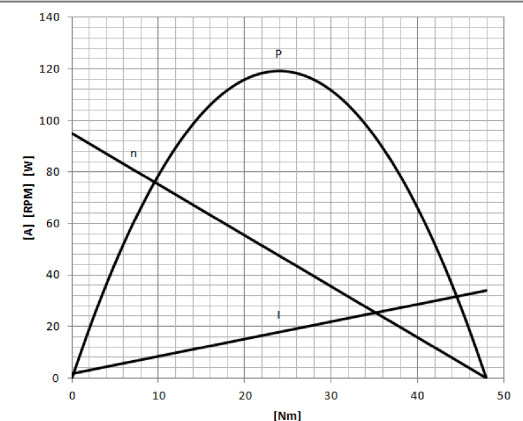

NOTAS:
Aplicação: Industrial

NOTES:
Application: Industrial